

# TELJESÍTMÉNYNYILATKOZAT

A 305/2011/EU számú, az építési termékek forgalmazására vonatkozó harmonizált feltételek megállapításáról szóló rendelet III. melléklete alapján

## Hilti CFS-CC tűzvédelmi kábelbilincs

Sz.: Hilti CFS-CC „0843-CPD-0151”

### 1. A terméktípus egyedi azonosító kódja:

Hilti CFS-CC tűzvédelmi kábelbilincs

### 2. Felhasználás:

Tűzvédelmi és tömítő termék áthatoló tömítésekhez, lásd: ETA-13/0704 (2018. 06. 28.)

Kábeláthatolások	Kábelek, kábelkötegek, vezetékek
------------------	----------------------------------

### 3. Gyártó:

HILTI Corporation, Feldkircherstrasse 100, 9494 Schaan, Liechtensteini hercegség

### 4. Az ACVP rendszere:

1. rendszer

### 5. Európai értékelési dokumentum:

EAD 350454-00-1104 „Tűzvédelmi és tömítő termékek – áthatoló tömítésekhez”

#### Európai műszaki értékelés:

ETA-13/0704 (2013. 06. 28.)

#### A műszaki értékelést végző szerv:

OIB (Österreichisches Institut für Bautechnik – Osztrák építőmérnöki intézet)

#### Értesített szerv(ek):

MPA Braunschweig, Sz. 0761

### 6. A nyilatkozat szerinti teljesítmény:

Jellemző tulajdonság	A nyilatkozatban szereplő teljesítmény / harmonizált műszaki előírás
Tűzzel szembeni viselkedés	E osztály az EN 13501-1 szerint
Tűzállóság	Lásd a mellékletet
Zaj elleni védelem	
Tartósság és használhatóság	

A fent nevezett termék teljesítménye megfelel a bejelentett teljesítményeknek. A 305/2011/EU rendeletnek megfelelően e teljesítménynyilatkozat kiadásáért kizárólag a fent nevezett gyártó a felelős.

A gyártó nevében és részéről aláíró személy:

Jessica Bello Salguero  
Termékmenedzser  
Tűzvédelmi üzletág  
Hilti Corporation

Martin Althof  
Minőségbiztosítási vezető  
Tűzvédelmi üzletág  
Hilti Corporation

## Intended use

"Hilti Firestop Cable Collar CFS-CC" is intended to form a penetration seal to temporarily or permanently reinstate the fire resistance performance of a separating element (wall or floor) where they have been provided with apertures, which are penetrated by various services.

The maximum opening size of the penetration seal is  $\varnothing$  108 mm, providing that the distances from the outer edge of the penetration seal are no lower than 20 mm. For more details see Annex C of the ETA.

"Hilti Firestop Cable Collar CFS-CC" can only be used as penetration seal for cables, metal pipes, plastic pipes or for mixed penetration (combination). Further details are given in Annex C of the ETA. Other parts or service support constructions shall not penetrate the penetration seal.

"Hilti Firestop Cable Collar CFS-CC" can be installed only in the types of separating elements as specified in the following table.

Separating element	Construction
Flexible walls	<ul style="list-style-type: none"><li>&gt; Steel studs or timber studs lined on both faces with minimum 2 layers of boards (minimum thickness 12,5 mm) according to EN 520 type F.</li><li>&gt; For timber stud walls there must be a minimum distance of 100 mm of the penetration seal to any timber stud. The cavity between the penetration seal and stud has to be closed with minimum of 100 mm of insulation with classification A1 or A2 according to EN 13501-1.</li><li>&gt; Minimum thickness 100 mm</li><li>&gt; This European Technical Assessment does not cover sandwich panel constructions.</li></ul>
Rigid walls	<ul style="list-style-type: none"><li>&gt; Aerated concrete, concrete, masonry</li><li>&gt; Minimum density 600 kg/m<sup>3</sup></li><li>&gt; Minimum thickness 100 mm</li><li>&gt; The rigid wall shall be classified in accordance with EN 13501-2 for the required fire resistance period</li></ul>
Rigid floors	<ul style="list-style-type: none"><li>&gt; Aerated concrete, concrete</li><li>&gt; Minimum density 550 kg/m<sup>3</sup></li><li>&gt; Minimum thickness 150 mm</li><li>&gt; The rigid floor shall be classified in accordance with EN 13501-2 for the required fire resistance period</li></ul>

## Resistance to fire

"Hilti Firestop Cable Collar CFS-CC" was tested according to EAD 350454-00-1104 clause 2.2.2, EN 1363-1 and EN 1366-3:2009.

Based upon the gained test results and the field of application specified within EN 1363-1 and EN 1366-3:2009 the penetration seal "Hilti Firestop Cable Collar CFS-CC" has been classified according to EN 13501-2:2007+A1:2009. The individual fire resistance classes are listed in Annex C.1 to C.4 of the ETA.

The maximum fire resistance class of the penetration seal in vertical or horizontal separating element depends on the fire resistance class of the penetrating elements. The fire resistance class of the penetration seal is reduced to the fire resistance class of the penetrating element with the lowest fire resistance classification.

## Airborne sound insulation

The airborne sound insulation of "Hilti Firestop Cable Collar CFS-CC" was tested according to EN ISO 10140-1 and EN ISO 10140-2. The rating of the sound insulation properties has been calculated in accordance with EN ISO 717-1.

The tests for airborne sound insulation were performed in a flexible wall element. The wall element was constructed from 92 mm wide metal (0,36 mm thick galvanised steel) studs spaced at 610 mm centres. The wall was clad on each side with a double layer of 16 mm thick gypsum wallboard and filled with 75 mm thick "Thermafiber" mineral wool insulation. The wall element had an area of 6,8 m<sup>2</sup>. "Hilti Firestop Cable Collar CFS-CC" was penetrated with a Ø 50 mm cable bundle located in a 100 mm pipe.

The reached values for the airborne sound insulation in accordance with EN ISO 717-1:1996+A1:2006 are as follows:

Flexible wall with "Hilti Firestop Cable Collar CFS-CC" on both sides; with steel pipe and cable bundle:

<b>R<sub>w</sub> in dB</b>	<b>C in dB</b>	<b>C<sub>tr</sub> in dB</b>
56	-2	-8

Flexible wall with "Hilti Firestop Cable Collar CFS-CC" on both sides; with steel pipe:

<b>R<sub>w</sub> in dB</b>	<b>C in dB</b>	<b>C<sub>tr</sub> in dB</b>
59	-3	-9

## Abbreviations used in drawings

<b>Abbreviation</b>	<b>Description</b>
A, A <sub>1</sub> , A <sub>2</sub> ,...	Hilti Firestop products
C, C <sub>1</sub> , C <sub>2</sub> ,...	Penetrating services
E, E <sub>1</sub> , E <sub>2</sub> ,...	Building elements (wall, floor)
S <sub>1</sub> , S <sub>2</sub> , S <sub>n</sub>	Distances
t <sub>A</sub>	Thickness of penetration seal
t <sub>E</sub>	Thickness of the building element
W <sub>P</sub>	Max diameter of seal penetration
W <sub>A</sub>	Width of frame

## RESISTANCE TO FIRE CLASSIFICATION OF PENETRATION SEALS MADE OF HILTI FIRESTOP CABLE COLLAR CFS-CC

### C.1 General Information

#### C.1.1 Wall / floor constructions

a) Flexible wall:

The wall must have a minimum thickness of 100 mm and comprise timber or steel studs lined on both faces with minimum 2 layers of 12.5 mm thick boards according to EN 520 type F.

In steel stud construction the space between linings has not to be completely filled with insulation material, especially in the neighbourhood to the seal. Nevertheless the wall has to be set up according to the requirements.

For timber stud walls there must be a minimum distance of 100 mm of the seal to any stud and the cavity between stud and seal must be closed and a minimum of 100 mm insulation of Class A1 or A2 (in accordance with EN 13501-1) in the cavity between stud and seal is necessary.

b) Rigid wall:

The wall must have a minimum thickness of 100 mm and comprise concrete, aerated concrete or masonry, with a minimum density of 600 kg/m<sup>3</sup>.

c) Rigid floor:

The floor must have a minimum thickness of 150 mm and comprise aerated concrete or concrete with a minimum density of 550 kg/m<sup>3</sup>.

The walls / floors must be classified in accordance with EN 13501-2 for the required fire resistance period or fulfil the requirements of the relevant Eurocode. This European Technical Assessment does not cover sandwich panel constructions.

#### C.1.2 Aperture frame / Board frame

The penetration seal depth is approximately 200 mm ( $t_A$ ) in walls and 250 mm ( $t_A$ ) in floors, comprising by at least a wall of 100 mm ( $t_E$ ) or a floor of 150 mm ( $t_E$ ) and two times the thickness of the cable collar.

An aperture frame is not necessary.

In some cases a board frame is used to thicken a 100 mm wall to 150 mm by two 12,5 mm boards on each side of the penetration seal. The remaining edges must have a minimum width of about 50 mm ( $W_A$ ).

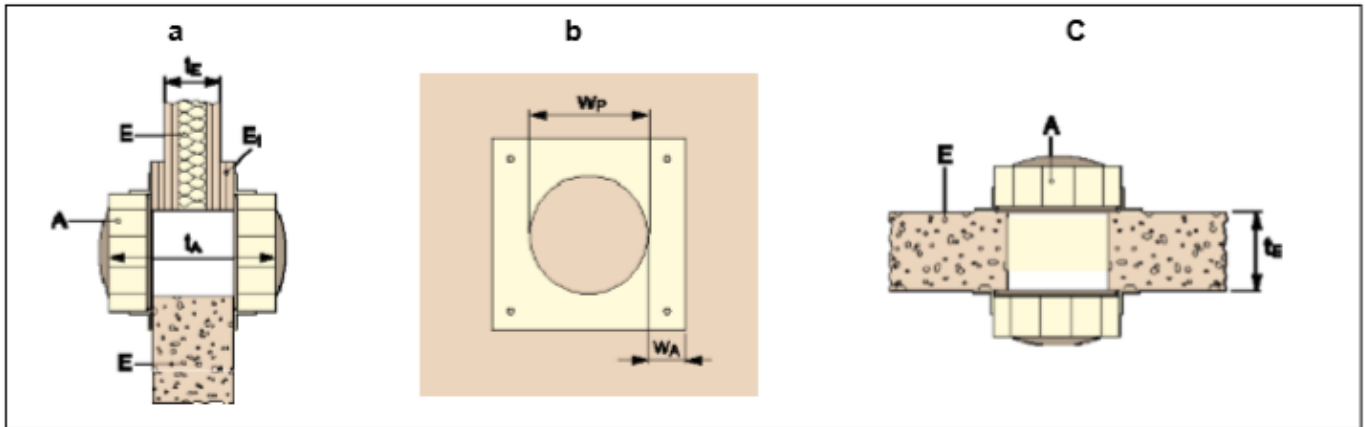

Figure 1: board frame (a, b) and position of the penetration seal in walls / floors (a,c)

<p>A Hilti Firestop Cable Collar CFS-CC</p> <p>E Separating element (flexible wall, rigid wall, rigid floor)</p> <p>E<sub>1</sub> Board frame</p> <p>t<sub>A</sub> Thickness of the penetration seal</p>	<p>t<sub>E</sub> Thickness of separating element</p> <p>W<sub>P</sub> Diameter of the aperture</p> <p>W<sub>A</sub> Width of the frame around the aperture</p>
--	--

### C.1.3 Maximum Seal Size

<ul style="list-style-type: none"> <li>• Cable collar inlay has to be cut to fit on penetrating cables</li> <li>• Maximum diameter of cut out part is approximately 108 mm (convex core, w), so a boundary stripe of approximately 20 mm inlay is left on the edge of the collar (Ø 150 mm).</li> </ul>	<p>Figure 2 is a top-down view of a cable collar with a central circular cutout. The diameter of the cutout is labeled as 'w'. The collar has a convex core and a boundary stripe. A label 'A' points to the collar's edge.</p>
---	---

Figure 2: maximum seal size (w)

## C.1.4 Penetration seal

### C.1.4.1 Basic sealing with Hilti Firestop Filler CFS-FIL ( $A_{1a}$ )

- Gaps between services and Hilti Firestop Cable Collar CFS-CC (A) are filled with Hilti Firestop Filler CFS-FIL ( $A_{1a}$ ), depth 20 mm.

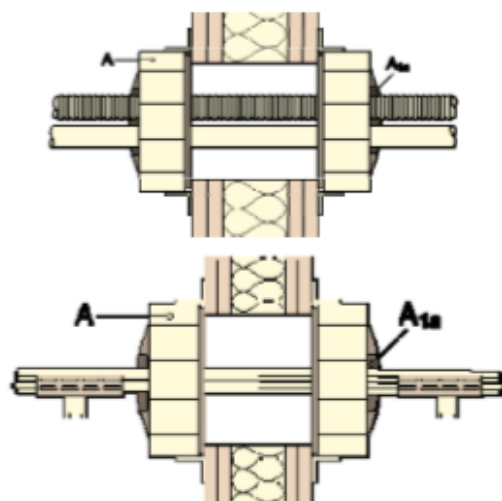

Figure 3: Filler ( $A_{1a}$ )

### C.1.4.2 Additional protection: Filler coating ( $A_{1b}$ )

- Gaps between penetrating elements and Hilti Firestop Cable Collar CFS-CC (A) are filled with Hilti Firestop Filler CFS-FIL ( $A_{1a}$ ), depth 20 mm.
- Cables covered by Hilti Firestop Filler CFS-FIL at 50 mm in length ( $t_R$ ) and approximately 5 mm in thickness ( $A_{1b}$ ).

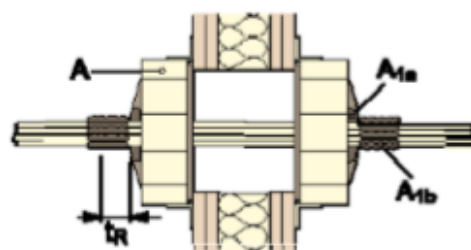

Figure 4: Filler Coating ( $A_{1b}$ ):

### C.1.4.3 Additional protection: Hilti Firestop Putty Bandage CFS-P BA ( $A_2$ )

- Gaps between penetrating elements and Hilti Firestop Cable Collar CFS-CC (A) filled with Hilti Firestop Filler CFS-FIL ( $A_{1a}$ ), depth 20 mm.
- Two layers of Hilti Firestop Putty Bandage CFS-P BA ( $A_2$ ) wrapped on each side around the services or group of services.

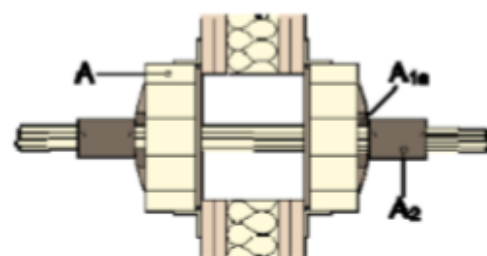

Figure 5: Filler ( $A_{1a}$ ) plus 2 layers of putty ( $A_2$ )

Hilti Firestop Putty Bandage CFS-P BA must be installed with the mesh outside/upside: The overlap of the putty wrapping must be at least 20 mm and is recommended to position on top or on the side. For floor applications, the use of Hilti Firestop Putty Bandage CFS-P BA is required on the top side only.

#### C.1.4.4 Additional sealing: mortar (floors only)

- Annular space between penetrating elements and floor edges filled with cementitious mortar.
- Gaps between penetrating elements and Hilti Firestop Cable Collar CFS-CC (A) filled with Hilti Firestop Filler CFS-FIL ( $A_{1a}$ ), depth 20 mm.
- Thickness of the penetration seal is about 200 mm (150 + 50 mm)

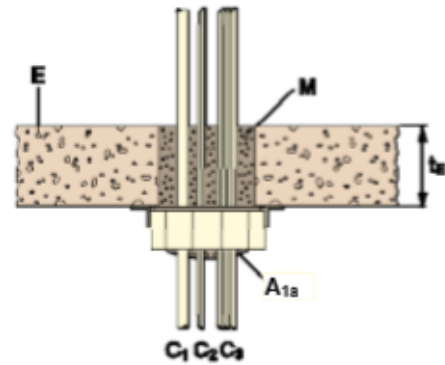

Figure 6: Mortar as gap filler (M)

#### C.1.5 Cluster arrangement

Minimum distances in mm (see illustration):

- $s_a$  = 0 (distance between cable collars linear)  
 $s_b$  = 0 (distance between cable collars in cluster arrangement)

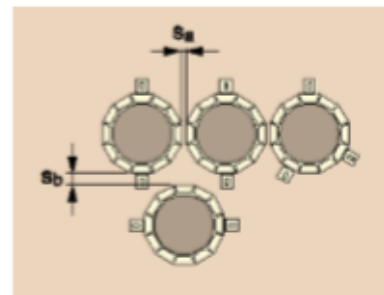

Figure 7

#### C.1.6 Distance Rule: Distances valid for wall and floor installations

Minimum distances in mm (see illustration):

- $s_1$  = 0 (distance between cables and seal edge)  
 $s_2$  = 0 (distance between cables or bundles)  
 $s_{20,21,22}$  = 0 (conduits  $\varnothing \leq 16$  mm)  
 $s_{20}$  = 0 (conduits  $\varnothing > 16$  mm; distance between conduits to each other)  
 $s_{21,22}$  = 15 (conduits  $\varnothing > 16$  mm distance of conduits to other services or seal border)

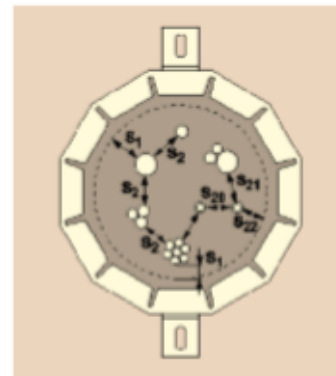

Figure 8

**C.2 Flexible or rigid walls according to Annex C.1.1 of the ETA - minimum wall thickness 100 mm**

**C.2.1 Blank seal (no services)**

Construction details (for symbols and abbreviations see Annex A.3 of the ETA)

- With two Hilti Firestop Cable Collars (A) a penetration seal with a thickness ( $t_A$ ) of approximately 200 mm is formed, centered to wall (E)
- $w$ :  $\varnothing$  of penetration, seal size

If services will be added later on in a blank seal only the services listed in the tables below may be added to fulfil the required classification

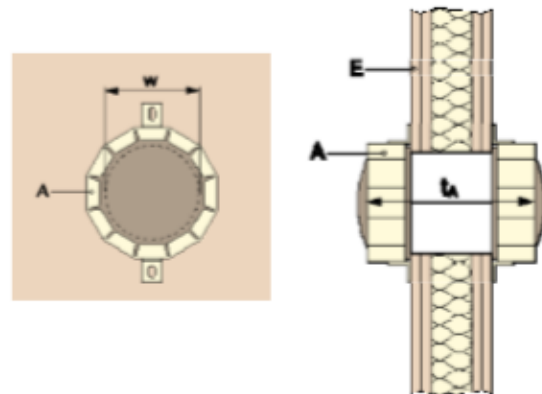

Figure 9: Blank seal

**Classification**

EI 120

Seal Size  $\varnothing$ : 108 mm

**C.2.2 Penetrating elements**

Services have to be supported at  $\leq 300$  mm from both faces of wall.

Hilti Firestop Cable Collars CFS-CC are mounted on the surface by the use of 2 to 3 fixing hooks evenly spaced around the penetration seal.

Abbreviation	Description
A, A <sub>1</sub> , A <sub>2</sub> ,...	Firestop products: A: Cable Collar A <sub>1a</sub> : Filler A <sub>2</sub> : Putty bandage
C, C <sub>1</sub> , C <sub>2</sub> ,...	Penetrating elements
E, E <sub>1</sub> , E <sub>2</sub> ,...	Building elements
$t_E$	Thickness of the building element

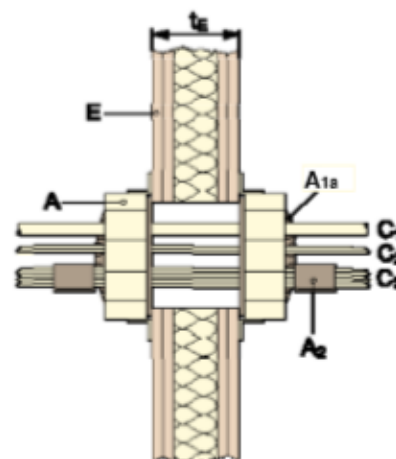

Figure 10: Flexible wall penetration



### C.2.2.a) Cables

#### Construction Details:

- Hilti Firestop Cable Collar CFS-CC (A), thickness of penetration seal ( $t_a$ )  $\leq$  200 mm
- Board frame (E1) according to Annex C.1.2. of the ETA
- Hilti Firestop Filler CFS-FIL ( $A_{1a}$ ) according to Annex C.1.4.1 of the ETA
- Filler coating with a length of 50 mm and a thickness of 5 mm ( $A_{1b}$ ), see Annex C.1.4.2 of the ETA
- Hilti Firestop Putty Bandage CFS-P BA, two layers on each side ( $A_2$ ), see Annex C.1.4.3 of the ETA
- For abbreviations see Annex A.3 of the ETA

For cable types (e.g. power, control, signal, telecommunication, data, optical fibre cables, with or without service support constructions) see the following classifications.

Additional protection	Classification			
	None	Filler Coating	Putty 2x	Board Frame
Wall thickness at penetration seal	100 mm			150 mm (100 + 2x25)
<u>All sheathed cable:</u>				
$\varnothing \leq 21$ mm ( $\varnothing$ 108 mm can be filled 100% with cable of this diameter)	EI 90/ E 120	-	EI 120	EI 120
$21 \leq \varnothing \leq 50$ mm	EI 60/ E 120	EI 90/ E 120	EI 90/ E 120	EI 90/ E 120
Tied cable bundle $\leq \varnothing$ 100 mm; $\varnothing$ single cable $\leq 21$ mm	EI 90/ E 120	-	EI 120	EI 120
Non-sheathed cables (wires) $\varnothing \leq 24$ mm	EI 30/ E 120		EI 60/ E 120	

### C.2.2.b) Small conduits and tubes

Construction details:

- Hilti Firestop Cable Collar CFS-CC (A), thickness of penetration seal ( $t_A$ )  $\leq$  200 mm
- Penetrating elements ( $C_1$ ) - see illustration Figure 10 in Annex C.2.2 of the ETA
- Hilti Firestop Filler CFS-FIL ( $A_{1a}$ ) according to Annex C.1.4.1 of the ETA
- For abbreviations see Annex A.3 of the ETA

$\varnothing \leq 16$  mm, wall thickness of conduit/tube  $\geq 1$  mm, arranged linear or clustered, with or without cables, with or without service support construction, minimum distance to each other = 0 mm

**Classification**

Plastic conduits and tubes

EI 120 U/U

Steel conduits and tubes

EI 120 C/U

### C.2.2.c) Conduits

Construction details:

- Hilti Firestop Cable Collar CFS-CC (A), thickness of penetration seal ( $t_A$ )  $\leq$  200 mm
- Penetrating elements ( $C_1$ ) - see illustration Figure 10 in Annex C.2.2 of the ETA
- Wall thickness of conduits: - PO: 1.2 to 2.30 mm - Polyolefin (PE, PP, PPE, PPO, ...)  
- PVC: 1.80 to 2 mm - Polyvinylchloride
- Hilti Firestop Filler CFS-FIL ( $A_{1a}$ ) according to Annex C.1.4.1 of the ETA
- For abbreviations see Annex A.3 of the ETA

		Diameter [mm]		Classification
		PO	PVC	
Flexible and rigid conduits: <i>Dietzel FXPYF/2232</i> <i>Dietzel FXOM/23341</i> <i>Fränkische-Kupla PFKu-EM-F-LS0H</i> <i>Marlay/Flex/2221</i> <i>Hegler HP-EPKMH 25</i> <i>Dietzel HFIRM 2242</i>	with and without cable	16 - 32	16 - 32	EI 120 U/U
Bundle of rigid or flexible conduits, $\varnothing$ of single conduits $\leq 32$ mm	with cable	$\leq 80$		EI 120 U/U
	without cable			EI 90 / E 120 U/U

### C.2.2.d) Waveguides (coaxial)

Construction details:

- Hilti Firestop Cable Collar CFS-CC (A), thickness of penetration seal ( $t_A$ )  $\leq$  200 mm
- Penetrating elements ( $C_1$ ) - see illustration Figure 10 in Annex C.2.2 of the ETA
- Hilti Firestop Filler CFS-FIL ( $A_{1a}$ ) according to Annex C.1.4.1 of the ETA
- For abbreviations see Annex A.3 of the ETA

Waveguides (coaxial):

**Classification**

*RFS Cellflex LCF 78-50 JA  $\varnothing$  27.8 mm*

*RFS Cellflex LCF 214-50 J  $\varnothing$  59.9 mm*

*RFS Heliflex HCA 78-50 JFNA  $\varnothing$  28.0 mm*

*RFS Heliflex HCA 158J  $\varnothing$  59.9 mm*

EI 90/ E 120 U/C

*RFS Radialflex RLKW 78-50  $\varnothing$  28.5 mm*

*RFS Radialflex RLKU 158-50 JFLA  $\varnothing$  48.2 mm*

EI 120 U/C

## C.3 Rigid floor according to Annex C.1.1 of the ETA, minimum floor thickness 150 mm

### C.3.1 Blank seal (no services)

Construction details (for symbols and abbreviations see Annex A.3 of the ETA)

- Hilti Firestop Cable Collar CFS-CC (A) is mounted on each side of the floor
- With two Hilti Firestop Cable Collars CFS-CC (A) a penetration seal with a thickness ( $t_A$ ) of approximately 250 mm is formed
- w:  $\varnothing$  of penetration, seal size

If services will be added later on in a blank seal only the services listed in the tables below may be added to fulfil the required classification

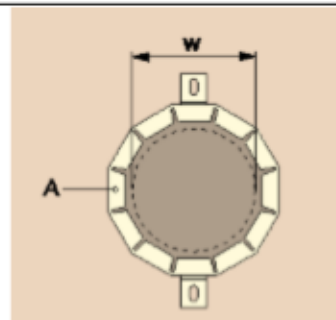

Figure 11: blank seal floor

**Classification**

Seal Size (w)  $\varnothing$ : 108 mm

EI 120

### C.3.2 Penetrating elements – floor application - 150 mm

Services have to be supported at  $\leq 300$  mm.

Hilti Firestop Cable Collars CFS-CC are fixed on the surface by 2 or 3 fixing hooks. Hooks have to be spaced at sufficient distance to each other. The maximum seal size is  $\varnothing 108$  mm.

Abbreviation	Description
A, A <sub>1</sub> , A <sub>2</sub> ,...	Firestop products: A: Cable Collar A <sub>1</sub> : Filler A <sub>2</sub> : Putty bandage
C, C <sub>1</sub> , C <sub>2</sub> ,...	Penetrating elements
E, E <sub>1</sub> , E <sub>2</sub> ,...	Building elements
t <sub>E</sub>	Thickness of the building element
M	Mortar

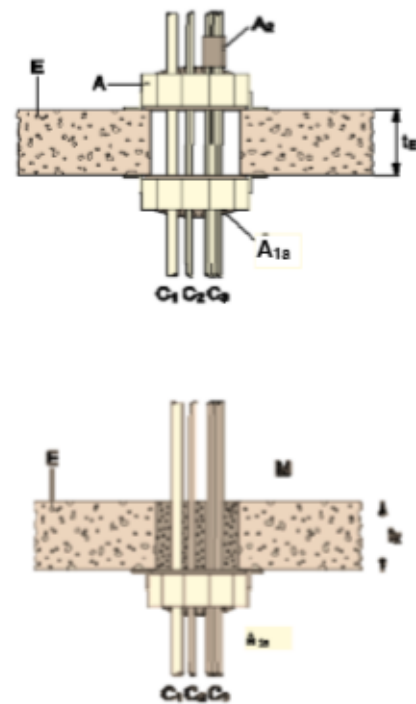

Figure 12: Floor penetration

#### C.3.2.a) Cables

Construction Details:

- Hilti Firestop Cable Collar CFS-CC (A), thickness of penetration seal (t<sub>A</sub>)  $\leq 250$  mm
- Hilti Firestop Filler CFS-FIL (A<sub>1a</sub>) according to Annex C.1.4.1 of the ETA
- Annular space between penetrating elements and floor edges filled with cementitious mortar, see Annex C.1.4.4 of the ETA
- Hilti Firestop Putty Bandage CFS-P BA, on upper side of floor only (A<sub>2</sub>), see Annex C.1.4.3 of the ETA
- Depending on the intended use, it is possible to use only one Hilti Firestop Cable Collar CFS-CC (A) on the bottom side of the floor, see the following classifications
- For abbreviations see Annex A.3 of the ETA

For cable types (e.g. power, control, signal, telecommunication, data, optical fibre cables, with or without service support constructions) see the following classifications.

Additional protection:	Classification	
	Gap Filler	Gap Filler + 2x Putty
<u>All sheathed cable:</u>		
$\varnothing \leq 21$ mm	EI 90 / E 120	EI 120
$\varnothing \leq 21$ mm (100% of cross section filled)	EI 120	EI 120
$21 \leq \varnothing \leq 50$ mm	EI 90 / E 120	EI 120
Tied cable bundle $\leq \varnothing 80$ mm; $\varnothing$ single cable $\leq 21$ mm	EI 120	EI 120
Non-sheathed cables (wires) $\varnothing \leq 24$ mm	EI 30 / E 120	EI 120

Hilti Firestop Cable Collar CFS-CC on bottom side of floor only, the annular space between penetration seal and floor edges filled with cementitious mortar according to Annex C.1.4.4 of the ETA.		
Additional protection:	Classification	
	Gap Filler + Mortar 1x Cable Collar	Gap Filler +Mortar 1x Cable collar 2x Putty
<u>All sheathed cable:</u>		
$\varnothing \leq 21$ mm	EI 120	EI 120
$\varnothing \leq 21$ mm (100% of cross section filled)	EI 120	EI 90 / E 120
$21 \leq \varnothing \leq 50$ mm	EI 60 / E 120	EI 120
Non-sheathed cables (wires) $\varnothing \leq 24$ mm	EI 90 / E 120	EI 120

### C.3.2.b) Small conduits and tubes

Construction details:

- Hilti Firestop Cable Collar CFS-CC (A) on both sides of the floor, thickness of penetration seal ( $t_a$ )  $\leq 250$  mm
- Penetrating elements ( $C_1$ ) - see illustration Figure 12 in Annex C.3.2 of the ETA
- Hilti Firestop Filler CFS-FIL ( $A_{1a}$ ) according to Annex C.1.4.1 of the ETA
- For abbreviations see Annex A.3 of the ETA

$\varnothing \leq 16$  mm, wall thickness of conduit/tube  $\geq 1$  mm, arranged linear, with or without cables, minimum distance to each other = 0 mm

**Classification**

Plastic conduits and tubes

EI 120 U/U

Steel conduits and tubes

EI 120 C/U

Tied bundle of conduits up to  $\varnothing 80$  mm

EI 120 U/U

### C.3.2.c) Conduits

Construction details:

- Hilti Firestop Cable Collar CFS-CC (A) on both sides of the floor, thickness of penetration seal ( $t_a$ )  $\leq 250$  mm
- Penetrating elements ( $C_1$ ) - see illustration Figure 12 in Annex C.3.2 of the ETA
- Hilti Firestop Filler CFS-FIL ( $A_{1a}$ ) according to Annex C.1.4.1 of the ETA
- For abbreviations see Annex A.3 of the ETA

Diameter [mm]

**Classification**

Flexible conduits:

*Dietzel FXPYF/2232*

*Dietzel FXOM/23341*

with and without cable

$16 \leq \varnothing \leq 32$

EI 120 U/U

Rigid conduits:

*Fränkische-Kupla FPKu-EM-F-LS0H*

*Fränkische-Isofix-EL-F*

with and without cable

$25 \leq \varnothing \leq 32$

EI 120 U/U

Rigid conduits:

*Fränkische-Isofix-EL-F*

*Hegler HP-EPKMH 25*

with and without cable

25

EI 120 U/U

Hilti Firestop Cable Collar CFS-CC on bottom side of floor only, the annular space between penetration seal and floor edges filled with cementitious mortar according to Annex C.1.4.4 of the ETA.

Diameter [mm]

**Classification**

Rigid and flexible conduits:

*Fränkische-Isofix-EL-F*

*Hegler HP-EPKMH 25*

with and without cable

25

EI 120 U/U

### C.3.2.d) Waveguides (coaxial)

Construction details:

- Hilti Firestop Cable Collar CFS-CC (A) on both sides of the floor, thickness of penetration seal ( $t_A$ )  $\leq$  250 mm
- Penetrating elements ( $C_1$ ) - see illustration Figure 12 in Annex C.3.2 of the ETA
- Hilti Firestop Filler CFS-FIL ( $A_{1a}$ ) according to Annex C.1.4.1 of the ETA
- For abbreviations see Annex A.3 of the ETA

Waveguides (coaxial):	Classification
<i>RFS Heliflex HCA 78-50J D <math>\varnothing</math> 28,0 mm</i> <i>RFS Heliflex HCA 158J <math>\varnothing</math> 50,4 mm</i>	EI 90 / E 120 - U/C
<i>RFS Cellflex LCF 78-50JA <math>\varnothing</math> 27,8 mm</i> <i>RFS Cellflex LCF 214-50J <math>\varnothing</math> 59,9 mm</i> <i>RFS Radialflex RLKW 78-50 JFNA <math>\varnothing</math> 28,5 mm</i> <i>RFS Radialflex RLKU 158-50 JFLA <math>\varnothing</math> 48,2 mm</i>	EI 120 - U/C

## C.4 Additional Application

Following additional applications are tested and proved to reach classification as stated above for both wall or floor installations. Deviations from before mentioned conditions or classifications are described.

### C.4.1 Protection of the edge of Hilti Firestop Cable Collar CFS-CC

In cases where damage of a cable might occur a rubber protection strip can be used on the inner edges of the metal cage

### C.4.2 Installation of a part of the Hilti Firestop Cable Collar CFS-CC

To fit Hilti Firestop Cable Collar CFS-CC to corner of wall / wall/ floor or wall/wall or wall/floor edges	<ul style="list-style-type: none"><li>• Up to 6 metal segments of the Hilti Firestop Cable Collar CFS-CC can be taken out (half size of the metal cage)</li><li>• Hilti Firestop Cable Collar CFS-CC is mounted with compression against the corner by pushing the tailored foam inlay. The inlay may comprise of two parts.</li><li>• At least two fixing hooks have to be used at sufficient distance to each other.</li></ul>
Perpendicular out-bending of cables	<ul style="list-style-type: none"><li>• Cables of size <math>\varnothing \leq 21</math> mm can be phased out in a perpendicular manner through Hilti Firestop Cable Collar CFS-CC along wall/floor. In parallel, additional cables might run straight through as in standard configuration.</li><li>• In this case up to 3 metal segments can be taken out to open space for cable penetration.</li><li>• Three fixing hooks have to be used for the fixation of Hilti Firestop Cable Collar CFS-CC</li><li>• For wall and floor application the classification is EI 120</li></ul>

#### **C.4.3 Special smoke guide pipe application**

The penetration of chemical high resistant smoke guide pipes made of ABS plastic (EN ISO 15493) with Ø 25 mm and a wall thickness of 2,3 mm, sealed with Hilti Firestop Cable Collar CFS-CC is assessed with a classification of EI 120 U/U

#### **C.4.4 Classification of split-type air conditioner services**

The penetration of insulated copper pipes including plastic condenser tubes of split-type air conditioner, sealed with Hilti Firestop Cable Collar CFS-CC is assessed with following classification:

- EI 120 C/U (Copper Pipe)
- EI 120 U/U (Condensation Pipe)
- EI 120 (cables)

Application:

- Sangi twin copper pipe 12/6 mm x 1,0 mm, insulated with PEP insulation of 9 mm thickness (Ø 30 or 24 mm)
- plastic condenser tube Ø 24 mm x 4,3 mm (Rehau Raufilam-E, flex PVC)
- electrical cables: two cables, each 5 x 1,5 mm<sup>2</sup>
- all services are bundled together with no distance in between

#### **C.4.5 Protection of isolated copper pipe Ø 22 mm**

The penetration of copper pipes, isolated with RS 800 Rockwool mineral wool (LS), protruding at a length of 200 mm on each side, sealed with Hilti Firestop Cable Collar CFS-CC is assessed with following classifications:

- Wall EI 90 / E 120 C/U
- Floor EI 120 C/U