

HU

TELJESÍTMÉNYNYILATKOZAT

A 305/2011. számú (EU) szabályozás (Construction Products Regulation - építési termék rendelet) III. melléklete alapján

Hilti S-MS Z, S-MS C önfúró csavarok
Hilti-SF-DoP-003 sz.

- 1. A terméktípus egyedi azonosító kódja:** Hilti S-MS Z, S-MS C önfúró csavarok
- 2. Típus-, köteg. vagy sorozatszám illetve bármely elem, amely lehetővé teszi az építési termék azonosítását a 11(4) cikkely által megkövetelt módon:** A csomagoláson feltüntetett típus- és tételszám
- 3. Az építési termék tervezett felhasználása vagy felhasználásai, a vonatkozó harmonizált műszaki specifikációnak megfelelően, a gyártó által előre látható módon:**

Általános típus és felhasználás	Önfúró rögzítőcsavarok fém elemekhez és lapokhoz
Az érintett termék mérete	Csavarátmérő: 4,8 mm
Alap- és rögzített anyag	Acél az EN 10346 szabvány előírásainak megfelelően Alumíniumötvözet az EN 485 / EN 573 szabvány előírásainak megfelelően,
Rögzítőanyag	Horganyzott vagy bevonatos, edzett szénacél az EN 10084 szabvány előírásainak megfelelően
Terhelés	Statikus és kvázistatikus (szélterhelés)

- 4. A gyártó neve, bejegyzett kereskedelmi neve vagy bejegyzett védjegye és levelezési címe a 11(5) cikkely által előírt módon:** Hilti Aktiengesellschaft, Business Unit Direct Fastening, 9494 Schaan, Fürstentum Liechtenstein

- 5. Ha alkalmazható, annak a meghatalmazott képviselőnek a neve és levelezési címe, akinek a meghatalmazottja elvégzi a 12(2) cikkelyben meghatározott feladatokat:** n.a.

- 6. Értékelési rendszer vagy rendszerek és az építési termék szilárdságának ellenőrzése az V. mellékletben meghatározottak szerint:** System 2+

- 7. Abban az esetben, a a teljesítménynyilatkozat harmonizált szabvány váltal érintett építési termékre vonatkozik:** n.a.

- 8. Olyan építési termékre vonatkozó teljesítménynyilatkozat esetén, amelyekre európai műszaki értékelést adtak ki:**
Az EAD 330046-01-0602 által kiadott ETA-10/0182 alapján. A tanúsítást végző MPA-Karlsruhe 0769 testület külső feladatokat végzett a 2+ rendszer alatt és kiadta a gyár termelésellenőrzésének megfelelőségi tanúsítványát.

- 9. A nyilatkozat szerinti teljesítmény:**

Jellemző tulajdonság	Teljesítmény	Harmonizált műszaki specifikáció
Jellemző húzási ellenállás $N_{R,k}$	1–6. melléklet ETA-10/0182 (4–9. melléklet)	ETA-10/0182 EAD 330046-01-0602
Jellemző nyírási ellenállás $V_{R,k}$		
Csatlakozás típusai		
Alkalmazási határok		
Tűzre adott reakció	A1	

- 10. Az 1. és 2. pontban meghatározott termék teljesítménye megfelel a 9. pontban meghatározott teljesítménynek. Ezt a teljesítménynyilatkozat a 4. pontban meghatározott gyártó kizárólagos felelőssége alapján került kibocsátásra.**

A gyártó nevében és részéről aláíró személy:

Lars Taenzer

Igazgató, közvetlen rögzítések részleg

Pierre Hohmeier

Igazgató, minőségi csavarkötések részleg

Hilti Aktiengesellschaft, Schaan, 03.05.2019.

Annex 1:
ETA-10/0182, Annex 4

	<p>Material:</p> <p>Fastener: carbon steel, case hardened and galvanized or coated</p> <p>Washer: none</p> <p>Component I: S280GD, S320GD, S350GD - EN 10346</p> <p>Component II: S280GD, S320GD, S350GD - EN 10346</p>																																																																																																																																																																																																																																										
	<p>Drilling capacity: $\Sigma t_i \leq 2,50$ mm</p>																																																																																																																																																																																																																																										
	<p>Timber substructures:</p> <p>no performance determined</p>																																																																																																																																																																																																																																										
<table border="1"> <thead> <tr> <th>t [mm]</th> <th colspan="8">t_i [mm]</th> </tr> <tr> <th></th> <th>0,50</th> <th>0,55</th> <th>0,63</th> <th>0,75</th> <th>0,88</th> <th>1,00</th> <th>1,13</th> <th>1,25</th> </tr> </thead> <tbody> <tr> <td rowspan="11">$V_{e,x}$ [kN]</td> <td>0,50</td> <td>1,29</td> <td>1,37</td> <td>1,51</td> <td>1,71</td> <td>1,71</td> <td>1,71</td> <td>1,71</td> <td>1,71</td> </tr> <tr> <td>0,55</td> <td>1,29</td> <td>1,54</td> <td>1,65</td> <td>1,82</td> <td>1,82</td> <td>1,82</td> <td>1,82</td> <td>2,05</td> </tr> <tr> <td>0,63</td> <td>1,29</td> <td>1,54</td> <td>1,80</td> <td>2,00</td> <td>2,00</td> <td>2,00</td> <td>2,00</td> <td>2,59</td> </tr> <tr> <td>0,75</td> <td>1,29</td> <td>1,54</td> <td>1,80</td> <td>2,27</td> <td>2,27</td> <td>2,27</td> <td>2,84</td> <td>3,40</td> </tr> <tr> <td>0,88</td> <td>1,29</td> <td>1,54</td> <td>1,80</td> <td>2,27</td> <td>2,96</td> <td>2,96</td> <td>2,96</td> <td>3,40</td> </tr> <tr> <td>1,00</td> <td>1,29</td> <td>1,54</td> <td>1,80</td> <td>2,27</td> <td>2,96</td> <td>3,64</td> <td>3,64</td> <td>3,64</td> </tr> <tr> <td>1,13</td> <td>1,29</td> <td>1,54</td> <td>1,80</td> <td>2,27</td> <td>2,96</td> <td>3,64</td> <td>3,87</td> <td>3,87</td> </tr> <tr> <td>1,25</td> <td>1,29</td> <td>1,54</td> <td>1,80</td> <td>2,27</td> <td>2,96</td> <td>3,64</td> <td>3,87</td> <td>4,10</td> </tr> <tr> <td>1,50</td> <td>1,29</td> <td>1,54</td> <td>1,80</td> <td>2,27</td> <td>2,96</td> <td>3,64</td> <td>—</td> <td>—</td> </tr> <tr> <td>1,75</td> <td>1,29</td> <td>1,54</td> <td>1,80</td> <td>2,27</td> <td>—</td> <td>—</td> <td>—</td> <td>—</td> </tr> <tr> <td>2,00</td> <td>1,29</td> <td>—</td> <td>—</td> <td>—</td> <td>—</td> <td>—</td> <td>—</td> <td>—</td> </tr> <tr> <td rowspan="11">$N_{e,x}$ [kN]</td> <td>0,50</td> <td>0,76</td> <td>0,87</td> <td>1,04</td> <td>1,29</td> <td>1,56</td> <td>1,82</td> <td>1,93</td> <td>1,93</td> </tr> <tr> <td>0,55</td> <td>0,76</td> <td>0,87</td> <td>1,04</td> <td>1,29</td> <td>1,56</td> <td>1,82</td> <td>2,09</td> <td>2,25</td> </tr> <tr> <td>0,63</td> <td>0,76</td> <td>0,87</td> <td>1,04</td> <td>1,29</td> <td>1,56</td> <td>1,82</td> <td>2,09</td> <td>2,34</td> </tr> <tr> <td>0,75</td> <td>0,76</td> <td>0,87</td> <td>1,04</td> <td>1,29</td> <td>1,56</td> <td>1,82</td> <td>2,09</td> <td>2,34</td> </tr> <tr> <td>0,88</td> <td>0,76</td> <td>0,87</td> <td>1,04</td> <td>1,29</td> <td>1,56</td> <td>1,82</td> <td>2,09</td> <td>2,34</td> </tr> <tr> <td>1,00</td> <td>0,76</td> <td>0,87</td> <td>1,04</td> <td>1,29</td> <td>1,56</td> <td>1,82</td> <td>2,09</td> <td>2,34</td> </tr> <tr> <td>1,13</td> <td>0,76</td> <td>0,87</td> <td>1,04</td> <td>1,29</td> <td>1,56</td> <td>1,82</td> <td>2,09</td> <td>2,34</td> </tr> <tr> <td>1,25</td> <td>0,76</td> <td>0,87</td> <td>1,04</td> <td>1,29</td> <td>1,56</td> <td>1,82</td> <td>2,09</td> <td>2,34</td> </tr> <tr> <td>1,50</td> <td>0,76</td> <td>0,87</td> <td>1,04</td> <td>1,29</td> <td>1,56</td> <td>1,82</td> <td>—</td> <td>—</td> </tr> <tr> <td>1,75</td> <td>0,76</td> <td>0,87</td> <td>1,04</td> <td>1,29</td> <td>—</td> <td>—</td> <td>—</td> <td>—</td> </tr> <tr> <td>2,00</td> <td>0,76</td> <td>—</td> <td>—</td> <td>—</td> <td>—</td> <td>—</td> <td>—</td> <td>—</td> </tr> <tr> <td>$M_{e,rot}$ [Nm]</td> <td colspan="8"></td> </tr> </tbody> </table>									t [mm]	t_i [mm]									0,50	0,55	0,63	0,75	0,88	1,00	1,13	1,25	$V_{e,x}$ [kN]	0,50	1,29	1,37	1,51	1,71	1,71	1,71	1,71	1,71	0,55	1,29	1,54	1,65	1,82	1,82	1,82	1,82	2,05	0,63	1,29	1,54	1,80	2,00	2,00	2,00	2,00	2,59	0,75	1,29	1,54	1,80	2,27	2,27	2,27	2,84	3,40	0,88	1,29	1,54	1,80	2,27	2,96	2,96	2,96	3,40	1,00	1,29	1,54	1,80	2,27	2,96	3,64	3,64	3,64	1,13	1,29	1,54	1,80	2,27	2,96	3,64	3,87	3,87	1,25	1,29	1,54	1,80	2,27	2,96	3,64	3,87	4,10	1,50	1,29	1,54	1,80	2,27	2,96	3,64	—	—	1,75	1,29	1,54	1,80	2,27	—	—	—	—	2,00	1,29	—	—	—	—	—	—	—	$N_{e,x}$ [kN]	0,50	0,76	0,87	1,04	1,29	1,56	1,82	1,93	1,93	0,55	0,76	0,87	1,04	1,29	1,56	1,82	2,09	2,25	0,63	0,76	0,87	1,04	1,29	1,56	1,82	2,09	2,34	0,75	0,76	0,87	1,04	1,29	1,56	1,82	2,09	2,34	0,88	0,76	0,87	1,04	1,29	1,56	1,82	2,09	2,34	1,00	0,76	0,87	1,04	1,29	1,56	1,82	2,09	2,34	1,13	0,76	0,87	1,04	1,29	1,56	1,82	2,09	2,34	1,25	0,76	0,87	1,04	1,29	1,56	1,82	2,09	2,34	1,50	0,76	0,87	1,04	1,29	1,56	1,82	—	—	1,75	0,76	0,87	1,04	1,29	—	—	—	—	2,00	0,76	—	—	—	—	—	—	—	$M_{e,rot}$ [Nm]								
t [mm]	t_i [mm]																																																																																																																																																																																																																																										
	0,50	0,55	0,63	0,75	0,88	1,00	1,13	1,25																																																																																																																																																																																																																																			
$V_{e,x}$ [kN]	0,50	1,29	1,37	1,51	1,71	1,71	1,71	1,71	1,71																																																																																																																																																																																																																																		
	0,55	1,29	1,54	1,65	1,82	1,82	1,82	1,82	2,05																																																																																																																																																																																																																																		
	0,63	1,29	1,54	1,80	2,00	2,00	2,00	2,00	2,59																																																																																																																																																																																																																																		
	0,75	1,29	1,54	1,80	2,27	2,27	2,27	2,84	3,40																																																																																																																																																																																																																																		
	0,88	1,29	1,54	1,80	2,27	2,96	2,96	2,96	3,40																																																																																																																																																																																																																																		
	1,00	1,29	1,54	1,80	2,27	2,96	3,64	3,64	3,64																																																																																																																																																																																																																																		
	1,13	1,29	1,54	1,80	2,27	2,96	3,64	3,87	3,87																																																																																																																																																																																																																																		
	1,25	1,29	1,54	1,80	2,27	2,96	3,64	3,87	4,10																																																																																																																																																																																																																																		
	1,50	1,29	1,54	1,80	2,27	2,96	3,64	—	—																																																																																																																																																																																																																																		
	1,75	1,29	1,54	1,80	2,27	—	—	—	—																																																																																																																																																																																																																																		
	2,00	1,29	—	—	—	—	—	—	—																																																																																																																																																																																																																																		
$N_{e,x}$ [kN]	0,50	0,76	0,87	1,04	1,29	1,56	1,82	1,93	1,93																																																																																																																																																																																																																																		
	0,55	0,76	0,87	1,04	1,29	1,56	1,82	2,09	2,25																																																																																																																																																																																																																																		
	0,63	0,76	0,87	1,04	1,29	1,56	1,82	2,09	2,34																																																																																																																																																																																																																																		
	0,75	0,76	0,87	1,04	1,29	1,56	1,82	2,09	2,34																																																																																																																																																																																																																																		
	0,88	0,76	0,87	1,04	1,29	1,56	1,82	2,09	2,34																																																																																																																																																																																																																																		
	1,00	0,76	0,87	1,04	1,29	1,56	1,82	2,09	2,34																																																																																																																																																																																																																																		
	1,13	0,76	0,87	1,04	1,29	1,56	1,82	2,09	2,34																																																																																																																																																																																																																																		
	1,25	0,76	0,87	1,04	1,29	1,56	1,82	2,09	2,34																																																																																																																																																																																																																																		
	1,50	0,76	0,87	1,04	1,29	1,56	1,82	—	—																																																																																																																																																																																																																																		
	1,75	0,76	0,87	1,04	1,29	—	—	—	—																																																																																																																																																																																																																																		
	2,00	0,76	—	—	—	—	—	—	—																																																																																																																																																																																																																																		
$M_{e,rot}$ [Nm]																																																																																																																																																																																																																																											
No additional regulations.																																																																																																																																																																																																																																											
Self piercing screw							Annex 4																																																																																																																																																																																																																																				
Hilti S-MS 01 Z 4,8 x L Hilti S-MS 01 C 4,8 x L with hexagon head																																																																																																																																																																																																																																											

Annex 2:
ETA-10/0182, Annex 5

	<p>Material:</p> <p>Fastener: carbon steel, case hardened and galvanized or coated</p> <p>Washer: carbon steel, galvanized or coated stainless Steel (1.4301) - EN 10088</p> <p>Component I: S280GD, S320GD, S350GD - EN 10346</p> <p>Component II: S280GD, S320GD, S350GD - EN 10346</p>																																																																																																																																																																																																																																																																	
	<p>Drilling capacity: $\Sigma t_i \leq 2,50$ mm</p>																																																																																																																																																																																																																																																																	
<p>Timber substructures: no performance determined</p>																																																																																																																																																																																																																																																																		
<table border="1"> <thead> <tr> <th rowspan="2"></th> <th rowspan="2">t_i [mm]</th> <th colspan="12">t_i [mm]</th> </tr> <tr> <th>0,40</th><th>0,50</th><th>0,55</th><th>0,63</th><th>0,75</th><th>0,88</th><th>1,00</th><th>1,25</th> </tr> </thead> <tbody> <tr> <td rowspan="8">V_{Rk} [kN]</td> <td>0,40</td><td>0,81</td><td>0,87</td><td>0,90</td><td>0,95</td><td>1,03</td><td>1,03</td><td>1,03</td><td>1,03</td><td>1,03</td><td>1,03</td><td>1,03</td><td>1,03</td> </tr> <tr> <td>0,50</td><td>0,81</td><td>1,01</td><td>1,01</td><td>1,02</td><td>1,03</td><td>1,03</td><td>1,03</td><td>1,03</td><td>1,03</td><td>1,03</td><td>1,03</td><td>1,03</td> </tr> <tr> <td>0,55</td><td>0,81</td><td>1,01</td><td>1,26</td><td>1,26</td><td>1,26</td><td>1,26</td><td>1,26</td><td>1,26</td><td>1,26</td><td>1,26</td><td>1,26</td><td>1,26</td> </tr> <tr> <td>0,63</td><td>0,81</td><td>1,01</td><td>1,26</td><td>1,66</td><td>1,66</td><td>1,66</td><td>1,66</td><td>1,66</td><td>1,66</td><td>1,66</td><td>1,66</td><td>1,66</td> </tr> <tr> <td>0,75</td><td>0,81</td><td>1,01</td><td>1,26</td><td>1,66</td><td>2,26</td><td>2,26</td><td>2,26</td><td>2,26</td><td>2,26</td><td>2,26</td><td>2,26</td><td>2,26</td> </tr> <tr> <td>0,88</td><td>0,81</td><td>1,01</td><td>1,26</td><td>1,66</td><td>2,26</td><td>2,77</td><td>2,77</td><td>2,77</td><td>2,77</td><td>2,77</td><td>2,77</td><td>2,77</td> </tr> <tr> <td>1,00</td><td>0,81</td><td>1,01</td><td>1,26</td><td>1,66</td><td>2,26</td><td>2,77</td><td>3,24</td><td>3,24</td><td>3,24</td><td>3,24</td><td>3,24</td><td>3,24</td> </tr> <tr> <td>1,25</td><td>0,81</td><td>1,01</td><td>1,26</td><td>1,66</td><td>2,26</td><td>2,77</td><td>3,24</td><td>4,24</td><td>4,24</td><td>4,24</td><td>4,24</td><td>4,24</td> </tr> <tr> <td rowspan="8">N_{Rk} [kN]</td> <td>0,40</td><td>0,46</td><td>0,76</td><td>0,88</td><td>1,03</td><td>1,27</td><td>1,43</td><td>1,43</td><td>1,43</td><td>1,43</td><td>1,43</td><td>1,43</td><td>1,43</td> </tr> <tr> <td>0,50</td><td>0,46</td><td>0,76</td><td>0,88</td><td>1,03</td><td>1,27</td><td>1,60</td><td>1,80</td><td>1,80</td><td>1,80</td><td>1,80</td><td>1,80</td><td>1,80</td> </tr> <tr> <td>0,55</td><td>0,46</td><td>0,76</td><td>0,88</td><td>1,03</td><td>1,27</td><td>1,60</td><td>1,90</td><td>1,90</td><td>1,90</td><td>1,90</td><td>1,90</td><td>1,90</td> </tr> <tr> <td>0,63</td><td>0,46</td><td>0,76</td><td>0,88</td><td>1,03</td><td>1,27</td><td>1,60</td><td>1,90</td><td>2,34</td><td>2,34</td><td>2,34</td><td>2,34</td><td>2,34</td> </tr> <tr> <td>0,75</td><td>0,46</td><td>0,76</td><td>0,88</td><td>1,03</td><td>1,27</td><td>1,60</td><td>1,90</td><td>2,49</td><td>2,49</td><td>2,49</td><td>2,49</td><td>2,49</td> </tr> <tr> <td>0,88</td><td>0,46</td><td>0,76</td><td>0,88</td><td>1,03</td><td>1,27</td><td>1,60</td><td>1,90</td><td>2,49</td><td>2,49</td><td>2,49</td><td>2,49</td><td>2,49</td> </tr> <tr> <td>1,00</td><td>0,46</td><td>0,76</td><td>0,88</td><td>1,03</td><td>1,27</td><td>1,60</td><td>1,90</td><td>2,49</td><td>2,49</td><td>2,49</td><td>2,49</td><td>2,49</td> </tr> <tr> <td>1,25</td><td>0,46</td><td>0,76</td><td>0,88</td><td>1,03</td><td>1,27</td><td>1,60</td><td>1,90</td><td>2,49</td><td>2,49</td><td>2,49</td><td>2,49</td><td>2,49</td> </tr> <tr> <td colspan="2">M_{Rk} [Nm]</td> <td colspan="12"></td> </tr> </tbody> </table>														t_i [mm]	t_i [mm]												0,40	0,50	0,55	0,63	0,75	0,88	1,00	1,25	V_{Rk} [kN]	0,40	0,81	0,87	0,90	0,95	1,03	1,03	1,03	1,03	1,03	1,03	1,03	1,03	0,50	0,81	1,01	1,01	1,02	1,03	1,03	1,03	1,03	1,03	1,03	1,03	1,03	0,55	0,81	1,01	1,26	1,26	1,26	1,26	1,26	1,26	1,26	1,26	1,26	1,26	0,63	0,81	1,01	1,26	1,66	1,66	1,66	1,66	1,66	1,66	1,66	1,66	1,66	0,75	0,81	1,01	1,26	1,66	2,26	2,26	2,26	2,26	2,26	2,26	2,26	2,26	0,88	0,81	1,01	1,26	1,66	2,26	2,77	2,77	2,77	2,77	2,77	2,77	2,77	1,00	0,81	1,01	1,26	1,66	2,26	2,77	3,24	3,24	3,24	3,24	3,24	3,24	1,25	0,81	1,01	1,26	1,66	2,26	2,77	3,24	4,24	4,24	4,24	4,24	4,24	N_{Rk} [kN]	0,40	0,46	0,76	0,88	1,03	1,27	1,43	1,43	1,43	1,43	1,43	1,43	1,43	0,50	0,46	0,76	0,88	1,03	1,27	1,60	1,80	1,80	1,80	1,80	1,80	1,80	0,55	0,46	0,76	0,88	1,03	1,27	1,60	1,90	1,90	1,90	1,90	1,90	1,90	0,63	0,46	0,76	0,88	1,03	1,27	1,60	1,90	2,34	2,34	2,34	2,34	2,34	0,75	0,46	0,76	0,88	1,03	1,27	1,60	1,90	2,49	2,49	2,49	2,49	2,49	0,88	0,46	0,76	0,88	1,03	1,27	1,60	1,90	2,49	2,49	2,49	2,49	2,49	1,00	0,46	0,76	0,88	1,03	1,27	1,60	1,90	2,49	2,49	2,49	2,49	2,49	1,25	0,46	0,76	0,88	1,03	1,27	1,60	1,90	2,49	2,49	2,49	2,49	2,49	M_{Rk} [Nm]													
	t_i [mm]	t_i [mm]																																																																																																																																																																																																																																																																
		0,40	0,50	0,55	0,63	0,75	0,88	1,00	1,25																																																																																																																																																																																																																																																									
V_{Rk} [kN]	0,40	0,81	0,87	0,90	0,95	1,03	1,03	1,03	1,03	1,03	1,03	1,03	1,03																																																																																																																																																																																																																																																					
	0,50	0,81	1,01	1,01	1,02	1,03	1,03	1,03	1,03	1,03	1,03	1,03	1,03																																																																																																																																																																																																																																																					
	0,55	0,81	1,01	1,26	1,26	1,26	1,26	1,26	1,26	1,26	1,26	1,26	1,26																																																																																																																																																																																																																																																					
	0,63	0,81	1,01	1,26	1,66	1,66	1,66	1,66	1,66	1,66	1,66	1,66	1,66																																																																																																																																																																																																																																																					
	0,75	0,81	1,01	1,26	1,66	2,26	2,26	2,26	2,26	2,26	2,26	2,26	2,26																																																																																																																																																																																																																																																					
	0,88	0,81	1,01	1,26	1,66	2,26	2,77	2,77	2,77	2,77	2,77	2,77	2,77																																																																																																																																																																																																																																																					
	1,00	0,81	1,01	1,26	1,66	2,26	2,77	3,24	3,24	3,24	3,24	3,24	3,24																																																																																																																																																																																																																																																					
	1,25	0,81	1,01	1,26	1,66	2,26	2,77	3,24	4,24	4,24	4,24	4,24	4,24																																																																																																																																																																																																																																																					
N_{Rk} [kN]	0,40	0,46	0,76	0,88	1,03	1,27	1,43	1,43	1,43	1,43	1,43	1,43	1,43																																																																																																																																																																																																																																																					
	0,50	0,46	0,76	0,88	1,03	1,27	1,60	1,80	1,80	1,80	1,80	1,80	1,80																																																																																																																																																																																																																																																					
	0,55	0,46	0,76	0,88	1,03	1,27	1,60	1,90	1,90	1,90	1,90	1,90	1,90																																																																																																																																																																																																																																																					
	0,63	0,46	0,76	0,88	1,03	1,27	1,60	1,90	2,34	2,34	2,34	2,34	2,34																																																																																																																																																																																																																																																					
	0,75	0,46	0,76	0,88	1,03	1,27	1,60	1,90	2,49	2,49	2,49	2,49	2,49																																																																																																																																																																																																																																																					
	0,88	0,46	0,76	0,88	1,03	1,27	1,60	1,90	2,49	2,49	2,49	2,49	2,49																																																																																																																																																																																																																																																					
	1,00	0,46	0,76	0,88	1,03	1,27	1,60	1,90	2,49	2,49	2,49	2,49	2,49																																																																																																																																																																																																																																																					
	1,25	0,46	0,76	0,88	1,03	1,27	1,60	1,90	2,49	2,49	2,49	2,49	2,49																																																																																																																																																																																																																																																					
M_{Rk} [Nm]																																																																																																																																																																																																																																																																		
<p>If both components I and II are made of S320GD or S350GD the grey highlighted values may be increased by 8,0%.</p>																																																																																																																																																																																																																																																																		
<p>Self piercing screw</p> <p>Hilti S-MS 41 Z 4,8 x L Hilti S-MS 41 C 4,8 x L Hilti S-MS 51 Z 4,8 x L Hilti S-MS 51 C 4,8 x L with hexagon head and sealing washer $\geq \varnothing 14$ mm</p>										<p>Annex 5</p>																																																																																																																																																																																																																																																								

Annex 3:
ETA-10/0182, Annex 6

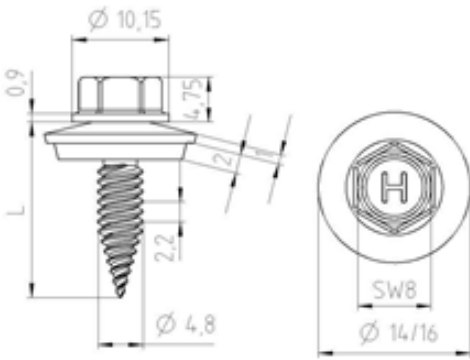

Material:

Fastener: carbon steel, case hardened and galvanized or coated

Washer: carbon steel, galvanized or coated
stainless Steel (1.4301) - EN 10088

Component I: aluminium alloy with $R_{m,min} = 215 \text{ N/mm}^2$ - EN 573

Component II: aluminium alloy with $R_{m,min} = 215 \text{ N/mm}^2$ - EN 573

Drilling capacity: $\Sigma t_i \leq 2,50 \text{ mm}$

Timber substructures:
no performance determined

t [mm]	t _i [mm]					
	0,50	0,60	0,70	0,80	1,00	1,20
V _{rel,k} [kN]	0,50	0,71	0,71	0,71	0,71	0,71
	0,60	0,71	0,92	0,92	0,92	0,92
	0,70	0,71	0,92	1,14	1,14	1,14
	0,80	0,71	0,92	1,14	1,35	1,35
	1,00	0,71	0,92	1,14	1,35	1,88
	1,20	0,71	0,92	1,14	1,35	1,88
N _{s,k} [kN]	0,50	0,35	0,49	0,52	0,52	0,52
	0,60	0,35	0,49	0,63	0,63	0,63
	0,70	0,35	0,49	0,63	0,73	0,73
	0,80	0,35	0,49	0,63	0,77	0,84
	1,00	0,35	0,49	0,63	0,77	1,00
	1,20	0,35	0,49	0,63	0,77	1,00
N _{R,ilk} [kN]	0,35	0,49	0,63	0,77	1,00	1,29
M _{torq,m} [Nm]						

The pull-through-capacities of the grey highlighted values $N_{s,k}$ have been determined according to EN 1999-1-4:2007 section 8.3.3.1 by calculation. This values $N_{s,k}$ may be increased by 6,9% when using the type „S-MS 5x“.

Self piercing screw	
Hilti S-MS 41 Z 4,8 x L Hilti S-MS 41 C 4,8 x L Hilti S-MS 51 Z 4,8 x L Hilti S-MS 51 C 4,8 x L with hexagon head and sealing washer $\geq \varnothing 14 \text{ mm}$	Annex 6

Annex 4:
ETA-10/0182, Annex 7

Material:

Fastener: carbon steel, case hardened and galvanized or coated

Washer: carbon steel, galvanized or coated stainless Steel (1.4301) - EN 10088

Component I: aluminium alloy with $R_{m,min} = 165 \text{ N/mm}^2$ - EN 573

Component II: aluminium alloy with $R_{m,min} = 165 \text{ N/mm}^2$ - EN 573

Drilling capacity: $\Sigma t_i \leq 2,50 \text{ mm}$

Timber substructures:
no performance determined

t [mm]	t _i [mm]						
	0,50	0,60	0,70	0,80	1,00	1,20	
V _{rel,k} [kN]	0,50	0,55	0,55	0,55	0,55	0,55	0,55
	0,60	0,55	0,71	0,71	0,71	0,71	0,71
	0,70	0,55	0,71	0,88	0,88	0,88	0,88
	0,80	0,55	0,71	0,88	1,04	1,04	1,04
	1,00	0,55	0,71	0,88	1,04	1,44	1,44
	1,20	0,55	0,71	0,88	1,04	1,44	1,83
N _{2,x} [kN]	0,50	0,27	0,38	0,40	0,40	0,40	0,40
	0,60	0,27	0,38	0,48	0,48	0,48	0,48
	0,70	0,27	0,38	0,48	0,56	0,56	0,56
	0,80	0,27	0,38	0,48	0,59	0,64	0,64
	1,00	0,27	0,38	0,48	0,59	0,76	0,80
	1,20	0,27	0,38	0,48	0,59	0,76	0,98
N _{2,lik} [kN]	0,27	0,38	0,48	0,59	0,76	1,03	
M _{1,10m} [Nm]							

The pull-through-capacities of the grey highlighted values N_{2,x} have been determined according to EN 1999-1-4:2007 section 8.3.3.1 by calculation. This values N_{2,x} may be increased by 6,9% when using the type „S-MS 5x“.

Self piercing screw	Annex 7
Hilti S-MS 41 Z 4,8 x L Hilti S-MS 41 C 4,8 x L Hilti S-MS 51 Z 4,8 x L Hilti S-MS 51 C 4,8 x L with hexagon head and sealing washer ≥ Ø14 mm	

Annex 5:
ETA-10/0182, Annex 8

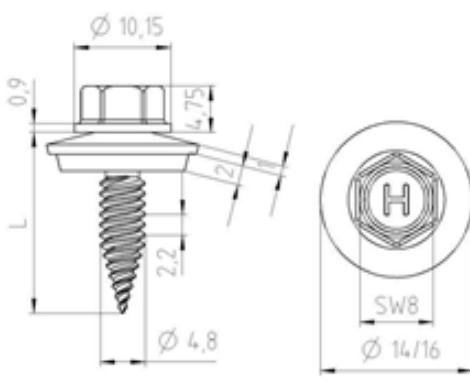

Material:

Fastener: carbon steel, case hardened and galvanized or coated

Washer: carbon steel, galvanized or coated
stainless Steel (1.4301) - EN 10088

Component I: aluminium alloy with $R_{m,min} = 215 \text{ N/mm}^2$ - EN 573

Component II: S280GD, S320GD, S350GD - EN 10346

Drilling capacity: $\Sigma t_i \leq 2,50 \text{ mm}$

Timber substructures:
no performance determined

t [mm]	t_i [mm]							
	0,50	0,55	0,63	0,75	0,88	1,00	1,25	
V_{Fck} [kN]	0,50	0,71	0,71	0,71	0,71	0,71	0,71	
	0,60	0,71	0,71	0,92	0,92	0,92	0,92	
	0,70	0,71	0,71	0,92	1,14	1,14	1,14	
	0,80	0,71	0,71	0,92	1,14	1,35	1,35	
	1,00	0,71	0,71	0,92	1,14	1,35	1,88	
	1,20	0,71	0,71	0,92	1,14	1,35	1,88	
N_{Rk} [kN]	0,50	0,52	0,52	0,52	0,52	0,52	0,52	
	0,60	0,63	0,63	0,63	0,63	0,63	0,63	
	0,70	0,73	0,73	0,73	0,73	0,73	0,73	
	0,80	0,76	0,84	0,84	0,84	0,84	0,84	
	1,00	0,76	0,87	1,04	1,05	1,05	1,05	
	1,20	0,76	0,87	1,04	1,26	1,26	1,26	
$N_{R,ilk}$ [kN]	0,76	0,87	1,04	1,28	1,58	1,86	2,42	
$M_{t,perm}$ [Nm]								

The pull-through-capacities of the grey highlighted values $N_{R,k}$ have been determined according to EN 1999-1-4:2007 section 8.3.3.1 by calculation. This values $N_{R,k}$ may be increased by 6,9% when using the type „S-MS 5x“.

Self piercing screw	
Hilti S-MS 41 Z 4,8 x L Hilti S-MS 41 C 4,8 x L Hilti S-MS 51 Z 4,8 x L Hilti S-MS 51 C 4,8 x L with hexagon head and sealing washer $\geq \varnothing 14 \text{ mm}$	Annex 8

Annex 6:
ETA-10/0182, Annex 9

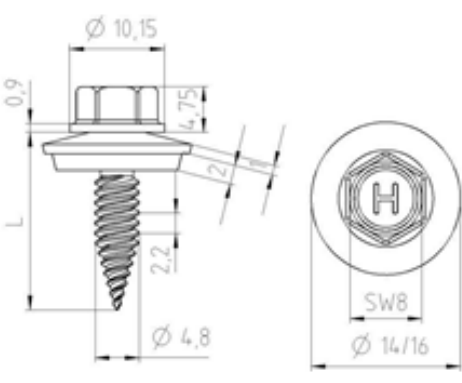

Material:

Fastener: carbon steel, case hardened and galvanized or coated

Washer: carbon steel, galvanized or coated stainless Steel (1.4301) - EN 10088

Component I: aluminium alloy with $R_{m,min} = 165 \text{ N/mm}^2$ - EN 573

Component II: S280GD, S320GD, S350GD - EN 10346

Drilling capacity: $\Sigma t_i \leq 2,50 \text{ mm}$

Timber substructures:
no performance determined

t [mm]	t _i [mm]							
	0,50	0,55	0,63	0,75	0,88	1,00	1,25	
V_{rel} [kN]	0,50	0,55	0,55	0,55	0,55	0,55	0,55	0,55
	0,60	0,55	0,55	0,71	0,71	0,71	0,71	0,71
	0,70	0,55	0,55	0,71	0,88	0,88	0,88	0,88
	0,80	0,55	0,55	0,71	0,88	1,04	1,04	1,04
	1,00	0,55	0,55	0,71	0,88	1,04	1,44	1,44
	1,20	0,55	0,55	0,71	0,88	1,04	1,44	1,83
N_{ex} [kN]	0,50	0,40	0,40	0,40	0,40	0,40	0,40	0,40
	0,60	0,48	0,48	0,48	0,48	0,48	0,48	0,48
	0,70	0,58	0,58	0,58	0,58	0,58	0,58	0,58
	0,80	0,64	0,64	0,64	0,64	0,64	0,64	0,64
	1,00	0,78	0,80	0,80	0,80	0,80	0,80	0,80
	1,20	0,78	0,87	0,96	0,96	0,96	0,96	0,96
N_{R,ilk} [kN]		0,76	0,87	1,04	1,28	1,58	1,86	2,42
M_{torq} [Nm]								

The pull-through-capacities of the grey highlighted values $N_{R,k}$ have been determined according to EN 1999-1-4:2007 section 8.3.3.1 by calculation. This values $N_{R,k}$ may be increased by 6,9% when using the type „S-MS 5x“.

Self piercing screw		Annex 9
Hilti S-MS 41 Z 4,8 x L Hilti S-MS 41 C 4,8 x L Hilti S-MS 51 Z 4,8 x L Hilti S-MS 51 C 4,8 x L with hexagon head and sealing washer $\geq \text{Ø}14 \text{ mm}$		